



St Norbert College

11 ATAR PHYSICS

Unit 2 – Linear Motion and Force

Task 9: Topic Test

Assessment type: Tests and Examinations
Year weighting: 6%

Student name:	
TOTAL	/ 50

Time allowed for this paper

Working time for paper: fifty (50) minutes

Materials required/recommended for this paper

To be provided by the supervisor

This Question/Answer Booklet

Formulae and Data Booklet

To be provided by the candidate

Standard items: pens (blue/black preferred), pencils (including coloured), sharpener, correction tape/fluid, eraser, ruler, highlighters

Special items non-programmable calculators approved for use in the WACE examinations, drawing templates, drawing compass and protractor

Important note to candidates

No other items may be taken into the examination room. It is **your** responsibility to ensure that you do not have any unauthorised notes or other items of a non-personal nature in the examination room. If you have any unauthorised material with you, hand it to the supervisor **before** reading any further.

Question 1

(10 marks)

In speedway, motorbikes are raced anticlockwise round an oval track.



A race consists of four laps of a 380 m track.

- (a) State the displacement of a motorbike from the start line to the finish line for a complete race. (1 mark)

- (b) The speed-time graph of a motorbike for the first 8.0 s of a race is shown.

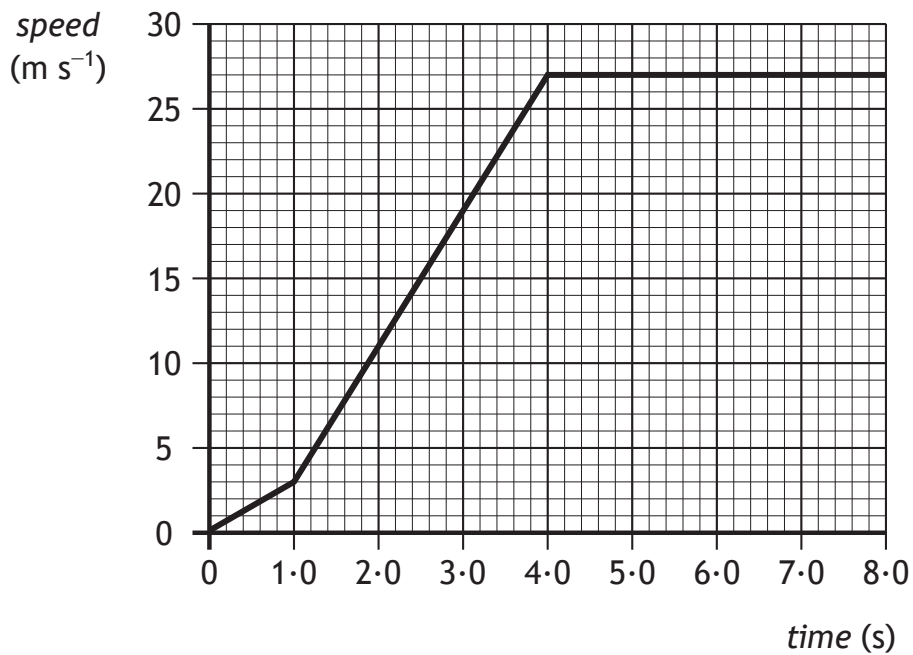

See next page

- (i) Calculate the distance travelled by the motorbike in the first 4.0 s of the race. (3 marks)
- (ii) Determine the greatest acceleration of the motorbike during the first 8.0 s of the race. (3 marks)
- (iii) The winner of the race completes all four laps in a time of 79 s. Calculate the average speed of the winner. (3 marks)

Question 2

(9 marks)

A hot air balloon rises with a vertical velocity of 7.0 m s^{-1} . A steady wind pushes the balloon with a horizontal velocity v . This is shown in the figure below.

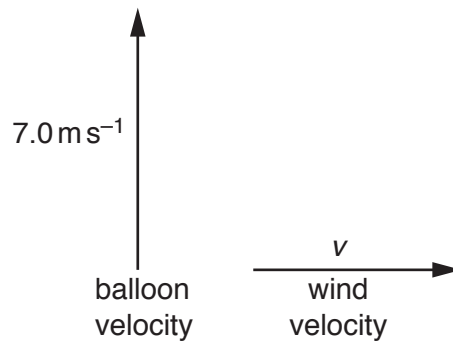

The magnitude of the resultant velocity of the balloon is 8.8 m s^{-1} .

- (a) On the figure above, draw an arrow labelled **R** to show the approximate direction of the resultant velocity of the balloon. (1 mark)
- (b) State why the magnitude of the resultant velocity of the balloon is not the sum of the speeds of the balloon and the wind. (1 mark)

- (c) With the help of a vector triangle, determine the magnitude of the wind velocity v and the angle θ between the resultant velocity of the balloon and the horizontal. (4 marks)

- (d) The figure below shows another balloon travelling with constant velocity 9.3 m s^{-1} .

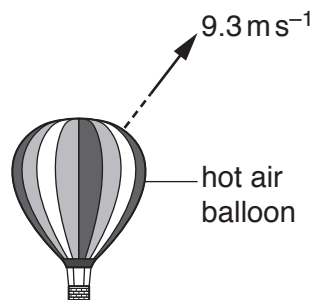

Apart from the upthrust and the wind there are two other forces acting on the balloon. State these two forces.

Draw labelled arrows on the figure to indicate their approximate directions. State the direction of the resultant of these two forces. (3 marks)

Question 3

(6 marks)

A tennis ball is thrown vertically downwards and bounces on the ground. The ball leaves the hand with an initial speed of 1.50 m s^{-1} at a height of 0.650 m above the ground. The ball rebounds and is caught when travelling upwards with a speed of 1.00 m s^{-1} . Assume that air resistance is negligible.

- (a) Show that the speed of the ball is about 4 m s^{-1} just before it strikes the ground.

(3 marks)

- (b) The ball is released at time $t = 0$. It hits the ground at time t_A and is caught at time t_B . On the figure below, sketch a velocity–time graph for the vertical motion of the tennis ball from when it leaves the hand to when it returns. The initial velocity **X** and final velocity **Y** are marked on the figure. (3 marks)

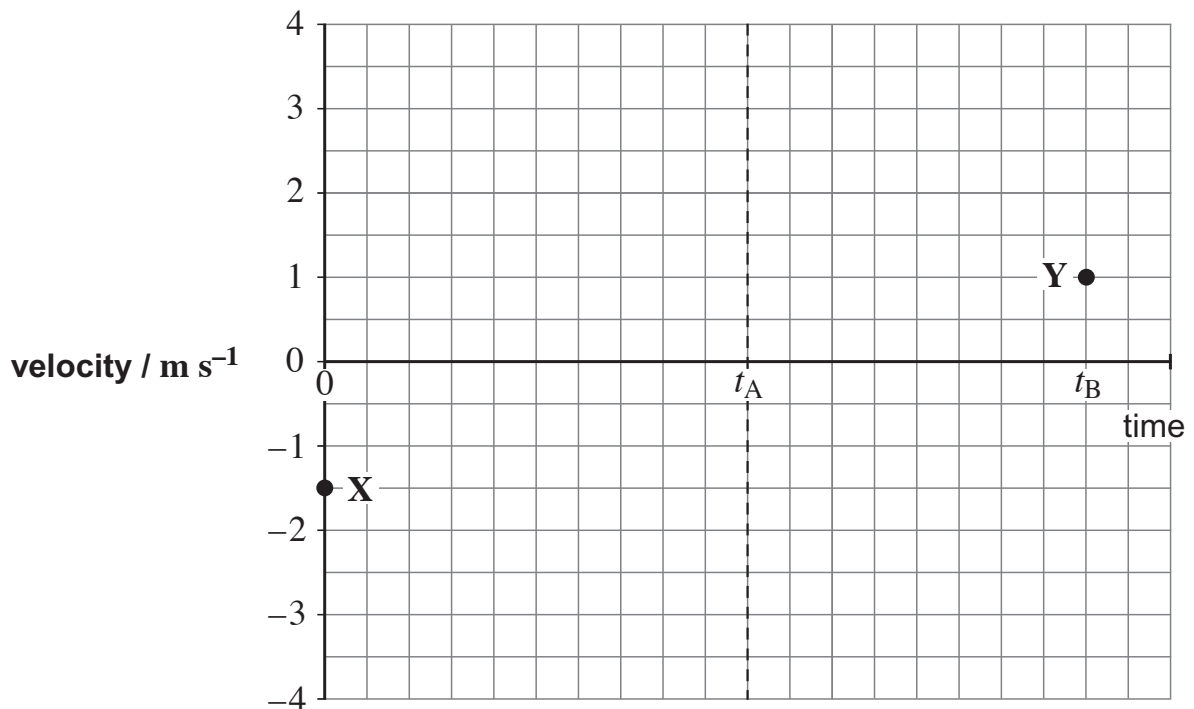

See next page

Question 4

(11 marks)

A leisure-park ride consists of a carriage that moves along a railed track. Part of the track lies in a vertical plane and follows an arc XY of a circle of radius 13.0 m, as shown in the figure below.

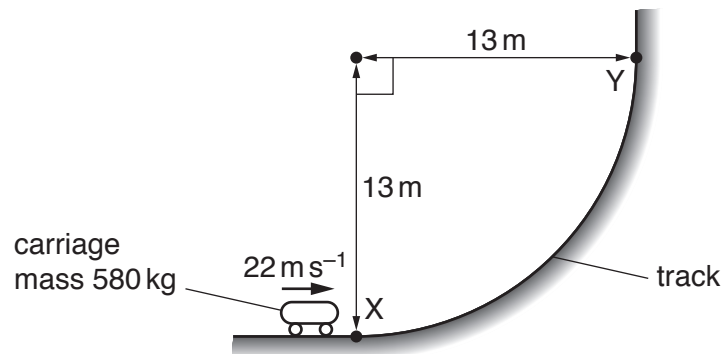

The mass of the carriage is 580 kg. At point X, the carriage has velocity 22.0 m s⁻¹ in a horizontal direction. The velocity of the carriage then decreases to 12.0 m s⁻¹ in a vertical direction at point Y.

(a) For the carriage moving from X to Y;

(i) Show that the decrease in kinetic energy is 9.9×10^4 J. (2 marks)

(ii) calculate the gain in gravitational potential energy. (2 marks)

(b) Show that the length of the track from X to Y is 20 m. (1 mark)

(c) Use your answers in (a) and (b) to calculate the average resistive force acting on the carriage as it moves from X to Y. (2 marks)

(d) Describe the change in the direction of the linear momentum of the carriage as it moves from X to Y. (1 mark)

(e) Determine the magnitude of the change in linear momentum when the carriage moves from X to Y. (3 marks)

Question 5

(7 marks)

A student sets up an experiment to investigate a collision between two vehicles on a frictionless air track.

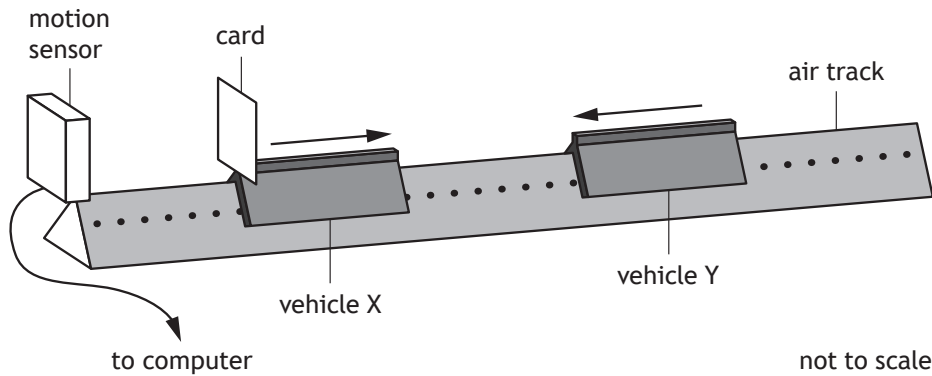

Vehicle X of mass of 0.75 kg is travelling to the right along the track.

Vehicle Y of mass 0.50 kg is travelling to the left along the track with a speed of 0.30 m s^{-1} .

The vehicles collide and move off separately.

A computer displays a graph showing the velocity of vehicle X from just before the collision to just after the collision.

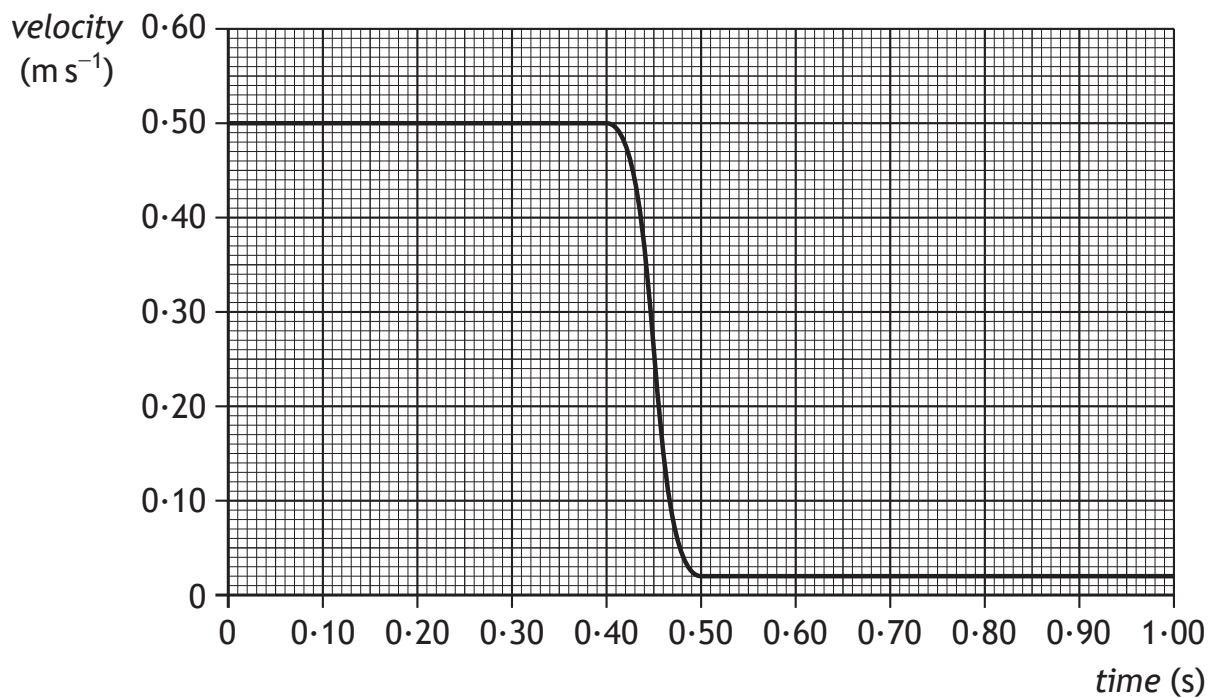

See next page

(a) Show that the velocity of vehicle Y after the collision is 0.42 m s^{-1} . (2 marks)

(b) Determine the impulse on vehicle Y during the collision. (3 marks)

- (c) Explain how the student would determine whether the collision was elastic or inelastic. (2 marks)

Question 6

(7 marks)

The photograph shows a solar-powered model boat built by some technology students.

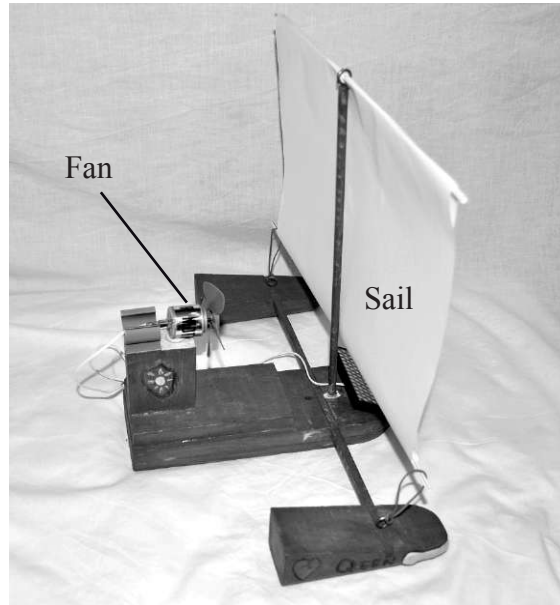

This boat has a solar-powered fan attached. The fan blows air towards the sail.

The technology students explain to a physics student that the fan exerts a force on the air and the air then exerts an equal force on the sail to drive the boat forwards. Assume that these two forces are equal for the rest of the question.

The physics student tells them that according to Newton's laws of motion this will not work.

- (a) The boat is placed in the water and the fan switched on. The boat remains at rest.

Add labelled arrows to the diagram below to show the four forces acting on the boat in this situation. (2 marks)

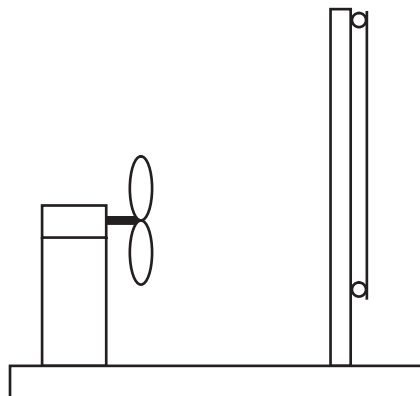

- (b) Use Newton's laws of motion to explain why the boat does not move horizontally. (3 marks)

- (c) The physics student suggests that the boat is more likely to work if the fan is reversed to point in the opposite direction. Explain this suggestion. (2 marks)
